

OILFREE

The pneumatic interval knocker FKL-100mi is featured with an integrated mechanic control.

This feature enabled the user to adjust the interval of the knocker and can be calibrate from 0,5 up to 200 impacts per minute.



The impacting force of the knocker can be set to three levels.

The knocker is supplied with a base plate used to attach the knocker and transmit the impact force. The knocker housing and knocker base plate are made of aluminium. The impact plate (integrated in the base plate) is made of special-purpose impact-resistant plastic.

Intermittent compressed air knockers can be used to dislodge material adhering to container walls (e.g. silos, hoppers, filter outlets, reactors and pipes).

The knockers can be used in wet areas or in open air.

Special editions for areas with high ambient temperature over 80°C or explosion-hazard areas are available.

PERFORMANCE DATA

	working pressure	work / knock	impuls / knock	weight	interval	air consumption / knock
model	bar	Nm	Ns	kg	impacts / minute	l
FKL-100mi	6 - 8	10 / 20 / 60	5 / 7,5 / 10	4,45	0,5 - 200	0,5 - 1,1

Data obtained with a Kistler 3-Axis Dynamometer on a heavy laboratory test block and displayed by a Kistler control monitor (COMO).

www.aldak.de • info@aldak.de

DIMENSIONS in mm

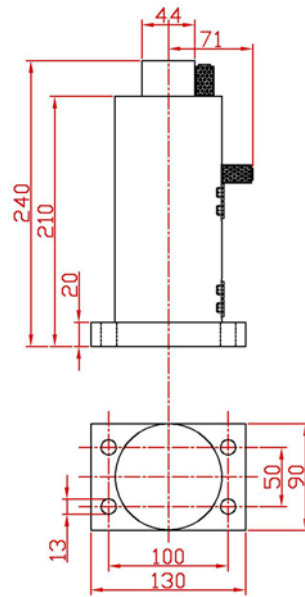

Standard installation for series FKL-mi:

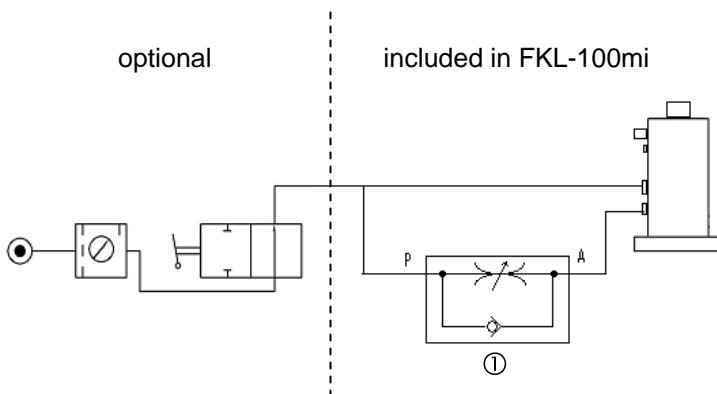

The control system of the knocker:

- air pressure supply
- maintenance unit* (with or without oiler)
- 3/2-way valve
- ① flow control valve
- pneumatic knocker FKL-100mi

* Use an air filter with a particle permeability rating of 5 µm.

We reserve the right to improve, modify or withdraw specifications or products without notice or obligation.

www.aldak.de • info@aldak.de